

MONTHS WARRANTY  
**24**  
MONTHS WARRANTY

# 5.18

# RTH



**MAGNI**  
TELESCOPIC HANDLERS

#### MAIN SECTORS



INDUSTRY



CONSTRUCTION

Maximum lifting height: 17.56 m  
Maximum reach: 14.26 m  
Electronically controlled hydrostatic transmission  
Automatic levelling device  
Pivoting stabilizers

MACHINE MODEL	Rotary telescopic handler	RTH 5.18		
	Maximum lifting capacity	4,999 kg (centre of gravity 500 mm)		
	Maximum lifting height	17.56 m		
	Rotation	360° (continuous)		
ENGINE	Type	<b>Deutz TCD 3,6 L4 Stage V</b>	<b>Deutz TCD 3,6 L4 Stage IV</b>	<b>Deutz TCD 3,6 L4 EDG Stage IIIA</b>
	Rated Power	100 kW (134 hp) @ 2,200 rpm		
	Maximum torque	500 Nm @ 1,600 rpm		
	Displacement	3.6 l		
	Cylinders	4 in line		
	Engine configuration	Turbocharged direct injection diesel		
	Cooling System	Water - intercooler		
TRANSMISSION	Type	Hydrostatic		
	Model	Danfoss / Rexroth		
	Maximum pressure	480 bar		
	Displacement	Electronically controlled variable displacement pump Variable displacement motor		
	Gearbox	Dropbox, 2 speeds forward-reverse		
AXLES AND BRAKES	Type	Axles with planetary gearboxes		
	Rear axle	Oscillating and steering with hydraulic locking		
	Front axle	Oscillating and steering with levelling +/-8°		
	Service brake	Hydraulically operated wet multi-disk brakes on each axle		
	Parking brake	Hydraulic with negative action		
	Tyre sizes	445/65 R22,5		
PERFORMANCE	Max. travel speed	40 km/h		
	Drawbar pull	72 kN		
	Gradeability	48%		
	Turning circle (at forks)	5,870 mm		
WEIGHTS	Total unladen	15,100 kg		
	Front axle unladen (boom retracted and lowered)	6,600 kg		
	Rear axle unladen (boom retracted and lowered)	8,500 kg		
TANK AND SYSTEM CAPACITIES	Diesel fuel tank	175 l	175 l	175 l
	AdBlue	10 l	10 l	-
	Hydraulic fluid	165 l	165 l	165 l
	Engine oil	9 l	9 l	9 l
	Cooling liquid	20 l	20 l	20 l
HYDRAULIC CIRCUIT FOR MOVEMENTS	Max. working pressure	350 bar		
	Circuit type	Load sensing		
	Service pump	Danfoss / Casappa - Variable displacement		
	Distributor for boom and turret movements	Danfoss - SIL 2 electro-proportional valve		
	Distributor for stabilisers	Bosch Rexroth - Electro-hydraulic actuators		
	Movements control	2 no. two-axis Danfoss joysticks with deadman safety device Managed via CAN bus		
STANDARDS MET	EN 1459-2: concerning standards for slewing variable-reach trucks EN 13000: concerning standards for hydraulic cranes EN 280: concerning standards for mobile elevating work platforms FOPS/ROPS EU 2016/1628: concerning engine emissions standards			

The data in this brochure are informative and subject to change without notice

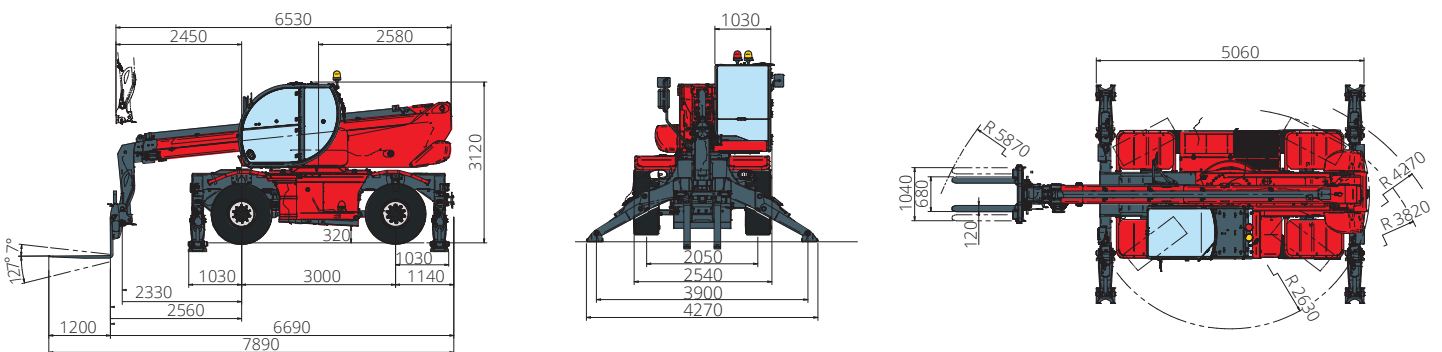

# ON STABILISERS

## 360° LOAD CHART ON FULLY EXTENDED STABILISERS

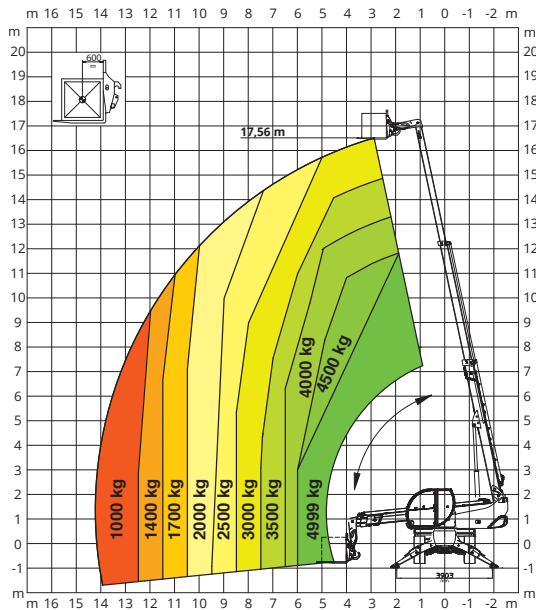

# ON TYRES

## FRONT LOAD CHART ON TYRES

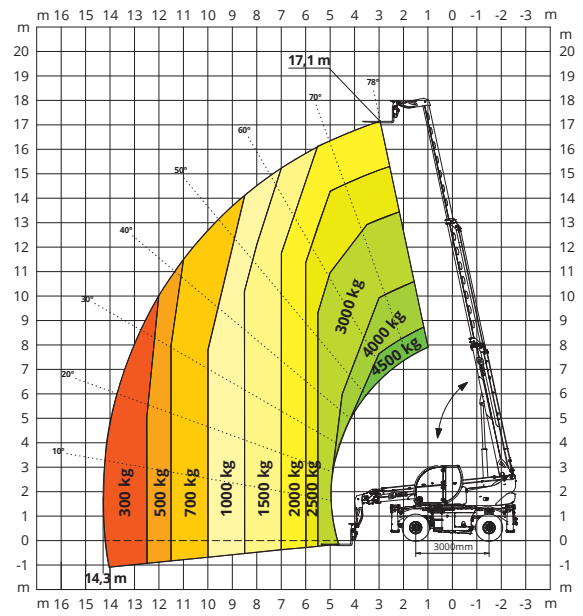

# W 3,5

## WINCH 3,500 kg

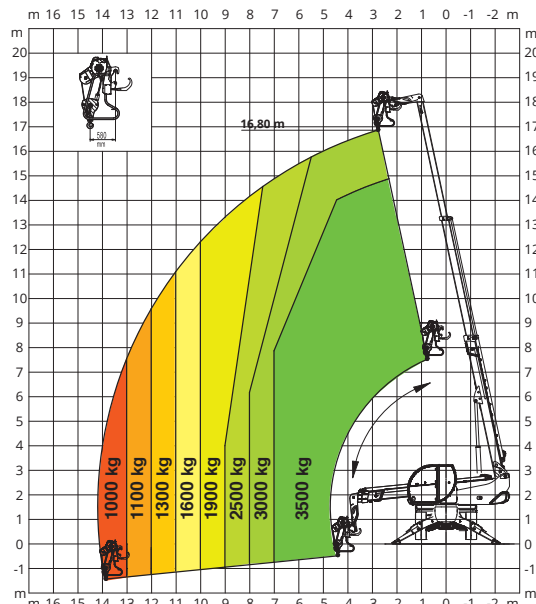

# W 5

## WINCH 5,000 kg

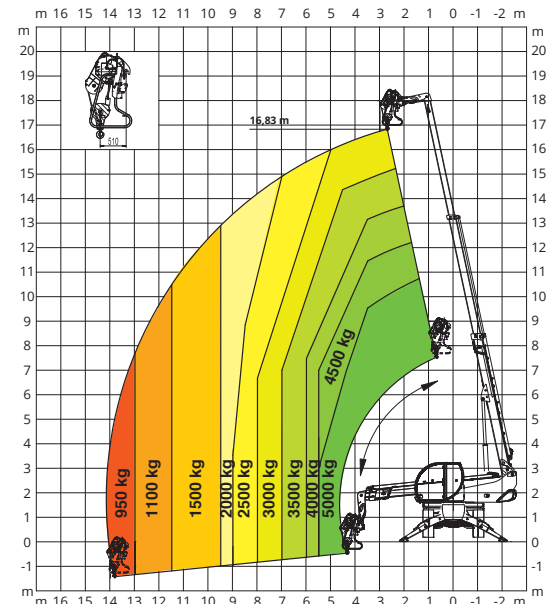

# JW 800

## JIB WITH WINCH 800 kg

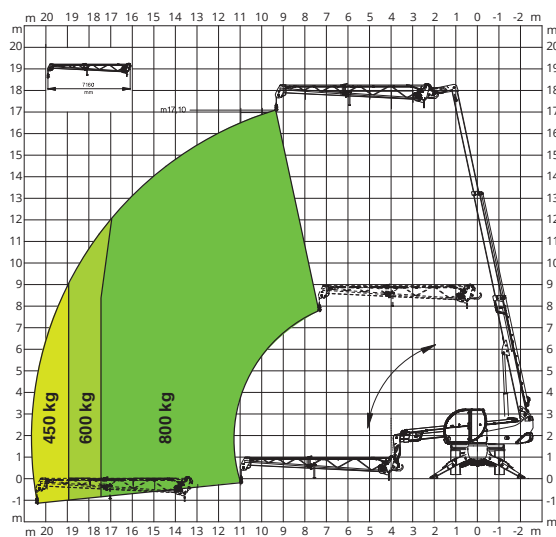

# JW 2000

## JIB WITH WINCH 2,000 kg

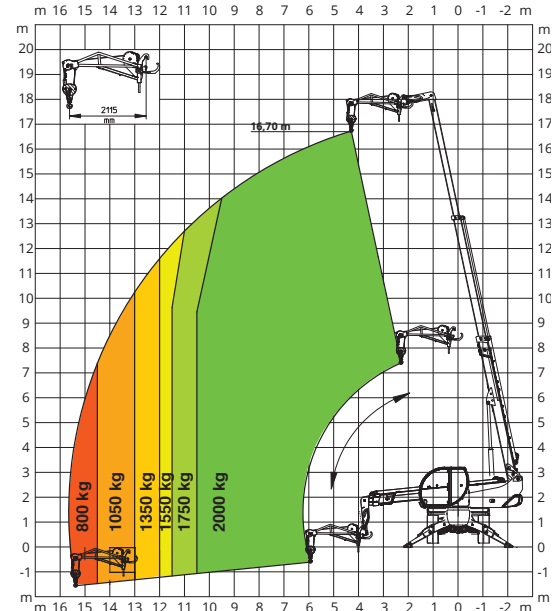

**J 2000**

**JIB 2,000 kg**

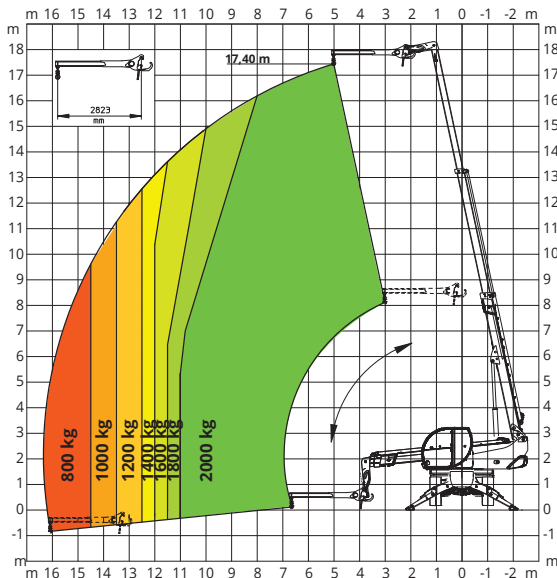

**REP 2-4,5**

**ROTATING EXTENDABLE BASKET 500 kg**

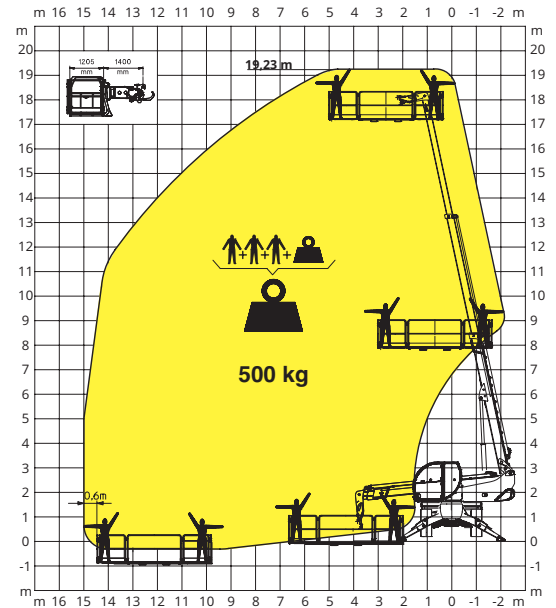

**REP 10.2-4,7**

**ROTATING EXTENDABLE BASKET 1,000 kg**

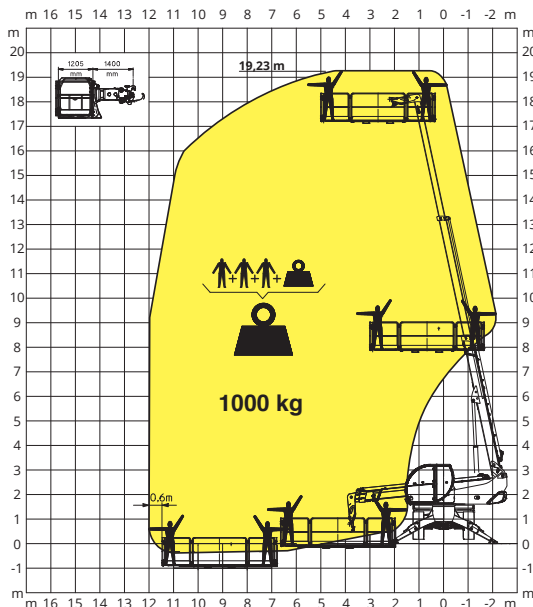

**TP**

**TELESCOPIC PIVOTING BASKET WITH 180° ROTATION**

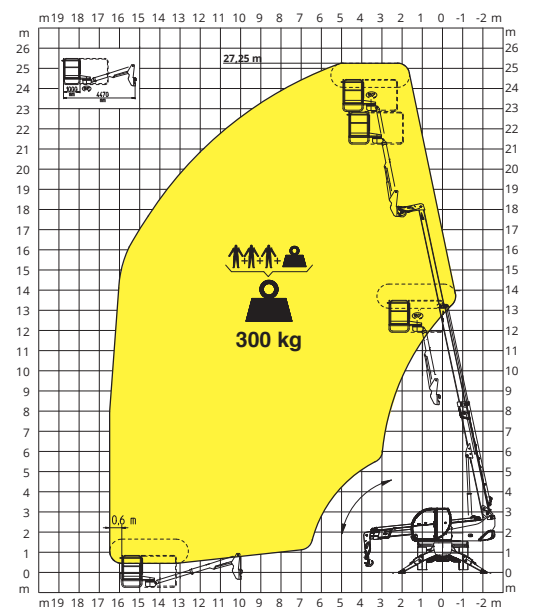

**TP O-U**

**TELESCOPIC PIVOTING OVER-UNDER BASKET WITH 340° ROTATION**

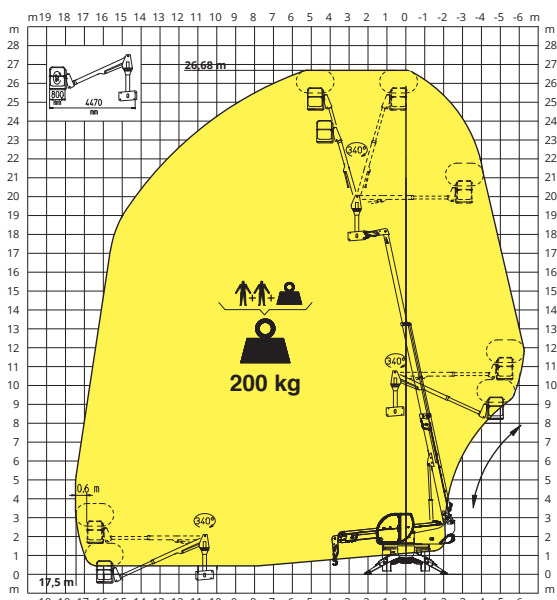

**TP O-U**

**TELESCOPIC PIVOTING OVER-UNDER BASKET WITH 340° ROTATION**

